

# Pneumatic Actuator – HTS105 ~270 Parts List

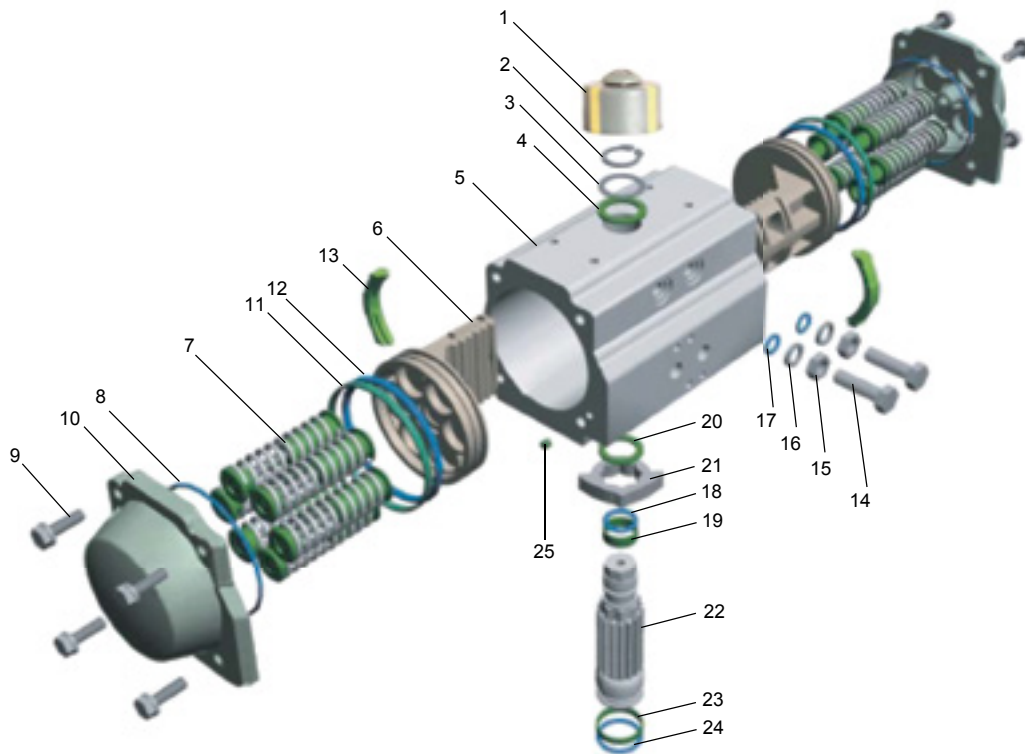

Item	Description	Material	Protection	Q'ty	Optional
1	Indicator	ABS		1	
2	Spring Clip	Stainless Steel		1	
3	Thrust Washer(Pinion)	Stainless Steel		1	
4	Thrust Bearing(Pinion)	PTFE+15%Graphite		1	
5	Actuator Body	Extruded Alluminum Alloy	Hard Anodized(over 30um)	1	Nickel or PTFE Plated
6	Piston	Die Cast Aluminum Alloy	Hard Anodized(over 30um)	2	
7	Spring(Cartridge)	High Performance Spring Steel	Electrophoretic Paint	0-12	
8*	End Cap Seals	NBR		2	Viton / Silicone
9	End Cap Bolts	Stainless Steel		8	
10	End Cap	Die Cast Aluminum	Epoxy Coated(over 150um)	2	Nickel or PTFE Plated
11*	Piston Bearing	POM		2	
12*	Piston Seal	NBR		2	Viton / Silicone
13*	Piston Guide	POM		2	
14	Stroke Bolt	Stainless Steel		2	
15	Stroke Bolt Retaining Nut	Stainless Steel		2	
16	Stroke Bolt Washer	Stainless Steel		2	
17*	Stroke Bolt O-Ring	NBR		2	Viton / Silicone
18*	O-Ring(Top Pinion)	NBR		1	Viton / Silicone
19*	Bearing(Top Pinion)	POM		1	
20*	Thrust Bearing(Pinion)	POM		1	
21	Stroke Cam	Carbon Steel	Galvanized	1	
22	Pinion	Alloy Steel	Nickel Plated(over 25um)	1	
23*	Bearing(Lower Pinion)	POM		1	
24*	O-Ring(Lower Pinion)	NBR		1	Viton / Silicone
25*	Plug	NBR		2	Viton / Silicone

\* Note: Recommended spare parts for maintenance.